

8612x

High-performance wavelength measurements for characterizing next-generation optical networks

# Multi-Wavelength Meters

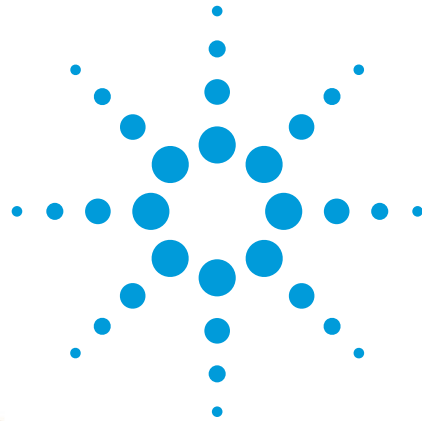

Agilent 86122A, 86120C & 86120B  
Multi-Wavelength Meters



Agilent Technologies

# The Agilent Family of Multi-Wavelength Meters

As consumers demand faster access to information and affordable bandwidth, the need for higher capacity transmission systems drives component manufacturers and network equipment manufacturers to push their capabilities to new limits while minimizing cost.

The successful design, manufacture and deployment of dense wavelength division multiplexing (DWDM) systems requires stringent performance criteria be met in order to ensure quality, uninterrupted communication.

To efficiently develop, manufacture, install and verify systems with this level of quality requires accurate, flexible, cost-effective and easy-to-use measurement tools. These tools must be optimized to help manufacturers reduce test costs and increase throughput to get products to market quickly and profitably.

## The performance you need - when you need it

Agilent Technologies' family of multi-wavelength meters offers a variety of performance options allowing you to choose the most cost-effective solution to meet even the most stringent test needs.



### New! 86122A Multi-Wavelength Meter

The 86122A offers the highest performance available in a multi-wavelength meter with absolute wavelength accuracy up to  $\pm 0.2$  ppm ( $\pm 0.3$  pm at 1550 nm). The new user interface features an enhanced graphical display for qualitative signal analysis of up to 1000 channels simultaneously. Coupled with new data analysis features and versatile LAN capabilities, the 86122A is optimized for performance in R&D and manufacturing environments.



### 86120B and 86120C Multi-Wavelength Meters

The performance and reliability that you've come to depend on is available in the 86120B and 86120C. The rugged and portable packaging makes these models an ideal tool to help ensure quality service by verifying system performance during commissioning, as well as monitoring system performance over time. Plus, the price/performance value offered by the 86120B and 86120C allows you to minimize test costs while ensuring quality.

**Tools must be optimized to help manufacturers reduce test costs and increase throughput**

# The Latest Addition to the Agilent Multi-Wavelength Meter Family

## Agilent 86122A Multi-Wavelength Meter

The new 86122A multi-wavelength meter from Agilent is designed to take you into the future of optical testing. New optical measurement performance options enable you to characterize next-generation DWDM systems and components in R&D and manufacturing. An enhanced graphical display and a full-featured user interface make signal analysis fast and efficient.

### Maximize performance while optimizing cost

The 86122A is offered with two performance options. Sub-picometer accuracy is affordable with the standard performance option that offers an absolute wavelength accuracy of  $\pm 0.5$  ppm ( $\pm 0.75$  pm at 1550 nm). And, when your needs demand the most advanced multi-wavelength meter, the 86122A's high-accuracy option provides  $\pm 0.2$  ppm ( $\pm 0.3$  pm at 1550 nm) absolute wavelength accuracy. Both options offer the ability to resolve up to 1000 channels spaced at  $< 5$  GHz and an update rate of two measurements per second, enabling fast measurements of densely spaced WDM carriers.

In addition to 100% code compatibility with the 86120C, the 86122A can be upgraded to high performance at any time. So, you can spend only as much as you need now and feel confident that your test equipment will meet your needs well into the future. Agilent multi-wavelength meters allow you to optimize test costs while protecting your investment.

### New user interface maximizes efficiency

The 86122A's touchscreen-based display provides for flexibility in viewing tabular data as well as an enhanced graphical view allowing quick qualitative analysis of your signal. With features like "Auto Measure" and "ClickZoom", the 86122A automatically optimizes the graphical and tabular view so you can begin testing immediately.

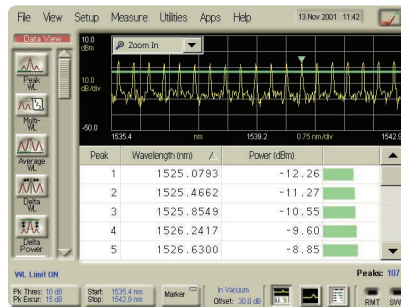

### Access to results allows quick and easy data analysis

The 86122A offers a built-in hard drive, floppy drive and LAN connection for easy data storage and retrieval. Save screen images in a variety of graphical formats so your results can be easily added to documents and presentations. Once you've configured the 86122A for use on the LAN, you can efficiently archive data to shared network drives or upgrade your firmware directly from the Internet.

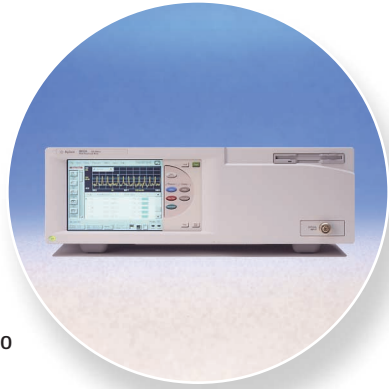

# The 86122A

### The 86122A automates data collection so you don't have to

The new data logging mode allows you to configure the 86122A to time-stamp and record measurement data at user-specified intervals over time without the need for remote programming. Collected data is saved to the instrument's internal hard drive in a Comma Separated Variable (.csv) file format. Data can be downloaded to a spreadsheet program for further analysis and integration in documents and presentations.

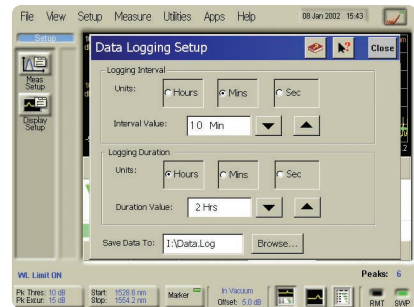

The 86122A is designed to take you into the future of optical testing.

# Measurement Applications

## DWDM Transmission Systems

As the pressure increases to provide profitable optical networks to meet consumer demand for affordable bandwidth, DWDM transmission system design is being pushed to the limits. While channel spacing continues to decrease accommodating more carriers and maximizing fiber usage, data rates continue to increase conveying more information per carrier. These system requirements make carrier wavelength and other optical parameter measurements even more critical.

Maximize the performance of optical transmission systems by accurately adjusting carrier wavelength, power and optical signal-to-noise ratio during design and manufacturing. Agilent multi-wavelength meters can simultaneously resolve and measure the individual optical carrier wavelengths and powers to confirm channel spacing, crosstalk, drift and optical signal-to-noise ratios.

**Carrier wavelengths and other optical parameters are critical for stringent system test requirements.**

## Optical Sources

Lasers are a key component to DWDM systems and subsystems. As system capabilities improve, manufacturers are challenged to develop and characterize more advanced components. For example, tunable lasers require repeated measurements, at each tuning wavelength, which can equate to hundreds of measurements per device.



Test equipment tools for these applications must be quick and accurate.

Optimize DFB, tunable lasers and Fabry-Perot lasers by accurately measuring wavelengths and amplitudes simultaneously with Agilent's multi-wavelength meters. Maximize and verify the source's performance during design, manufacturing, burn-in, environmental evaluation, final test, and incoming inspection.

## Test System Calibration

The high-performance wavelength measurement capability of the 86120C and 86122A allows you to verify the performance of other test equipment in your system. Use the multi-wavelength meter to verify the wavelength of your tunable laser source (TLS) in swept passive component testing. Or, measure the wavelength of the comb sources used to characterize EDFA's. Using a tunable laser source and a multi-wavelength meter, you can even calibrate the wavelength accuracy of your optical spectrum analyzer.

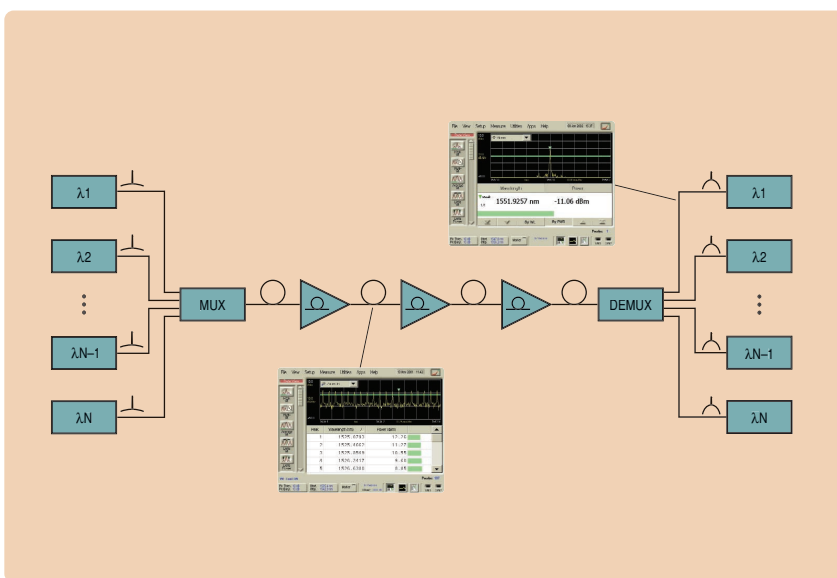



## Built-in Analysis Applications

### OSNR

Optical signal-to-noise ratio (OSNR) is an important parameter in DWDM system testing as it relates to bit-error-ratio (BER) performance. When using the OSNR application, the multi-wavelength meter automatically calculates OSNR normalized to a 0.1 nm bandwidth. Configure the application to measure noise between channels or at a user-defined wavelength. The averaging capability of the OSNR application minimizes uncertainty when measuring modulated signals.

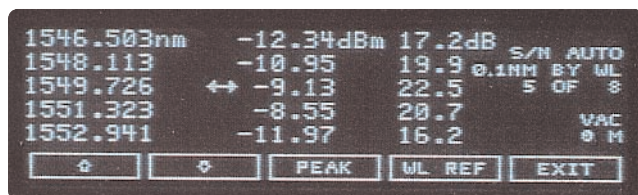

### Fabry-Perot Laser Characterization

Characterize Fabry-Perot laser sources quickly and easily using the built-in application in the 86120C and 86122A multi-wavelength meters. Get immediate results of:

- Total power
- Full-width at half-maximum
- Mean wavelength
- Mode spacing

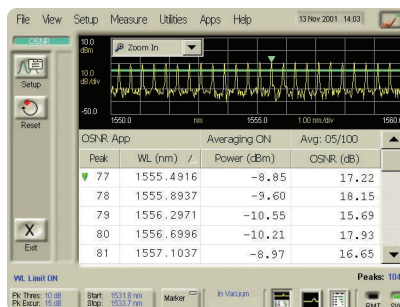
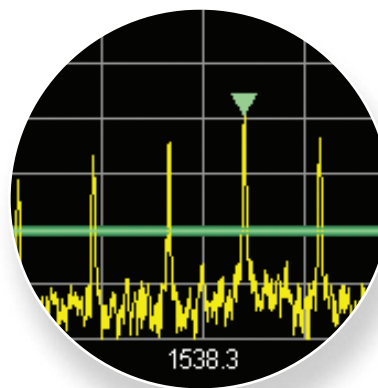

### Drift

Monitor wavelength and power of your input signal over time with the automated drift application. The drift application implemented in the 86122A also includes dropped-channel handling. This new capability identifies channels that have dropped, reappeared or appear as new compared to the reference sweep. Configure the application to measure:

- Current values—real-time status of your laser sources
- Maximum and minimum values—record the limits reached during the measurement
- Total drift—measure the total variation of signals during testing

### Coherence Length Measurement

The 86120B allows accurate measurements of the coherence length of Fabry-Perot laser sources typically used in CD-ROM drives or datacom transmission systems.

- Measurement range from 1 to 200 mm
- Accuracy within 5%
- Display laser coherence length and cavity optical length

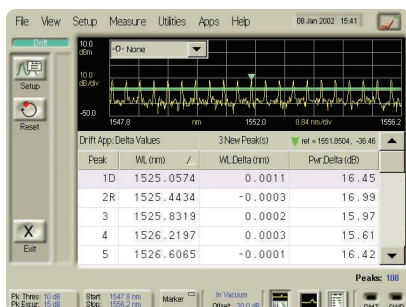
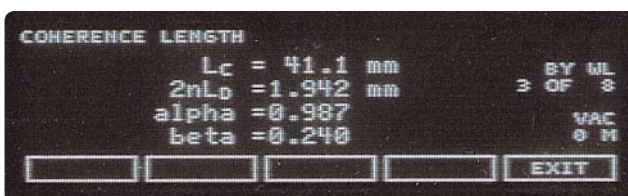

Built-in analysis applications make critical measurements fast and easy.

# The Performance You Need

## Enhanced graphical display

A color LCD with touchscreen allows fast qualitative analysis of input signals. View your spectrum in units of nm or THz on the graph, as well as the table.

## Menu toolbars

The various menu toolbars allow you access to all features without having to navigate nested menus.

## Graphical parameter control

Selectable graph controls for start/stop wavelength, center/span, and one-click zooming make optimizing your signal view fast and easy.

## ClickZoom

The graph and table are linked in the 86122A with the new ClickZoom feature. Click on a wavelength and the graph zooms in on that channel.



## Easily verify or change setup parameters

Key parameters like peak excursion and peak threshold are conveniently displayed and accessed from front panel buttons.

## Easy-to-read tabular display

Display the wavelength, power, delta, and OSNR of up to 1000 channels on the spreadsheet-like tabular display. The new ClickSort capability works like familiar PC applications to allow easy data sorting and viewing.

## Select tabular or graphical view

Maximize either the table or graph at the touch of a button for easy viewing of the information you need most.

## Save or print at the touch of a button

Data and screen captures can be saved in a variety of familiar formats by touching the "Save Data" or "Print" button conveniently located on the front panel.



# Features

## Auto Measure

Allow the 86122A to quickly optimize your signal view for you. The Auto Measure function zooms in on your signal and sets the optimal view in the tabular display.

## Touchkey controls

Top-level functions are conveniently located on the touchkey panel. This allows easy navigation of front-panel functions.



## Automatic measurement applications

The Applications touchkey activates the Applications toolbar in order to launch the built-in analysis applications:

- Drift
- OSNR
- Fabry-Perot Characterization

## Performance and reliability

The 86120B and 86120C continue to live up to the highest standards of reliability and performance that you've come to expect from Agilent's multi-wavelength meters.

- Measure up to 200 wavelengths and powers simultaneously
- 60 dB measurement range
- Up to 10 GHz signal resolution
- Ruggedized, portable packaging

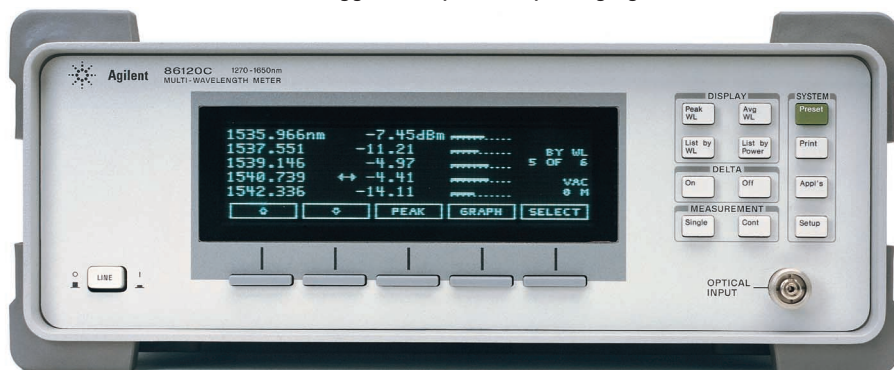

# Solutions Ideal for Design Through Commissioning

## Research and Development

New technologies currently in research and development need leading-edge test equipment to speed time-to-market. Measurement tools must have the performance to enable characterization of next-generation systems. These tools must also have features that maximize user efficiency in a laboratory environment.



The 86122A provides the performance that is crucial for characterizing next-generation DWDM transmission systems. The absolute wavelength accuracy of up to  $\pm 0.2$  ppm ( $\pm 0.3$  pm

at 1550 nm) and the ability to resolve channels spaced at  $< 5$  GHz make the 86122A multi-wavelength meter the optimum choice for design of densely-spaced WDM systems.

Designed to meet your needs in R&D, the new graphical display with marker and zoom capabilities allows quick and easy qualitative analysis of the input signal. Easily identify missing channels, erroneous center wavelength, and spectral flatness with a glance at the graph.

The touchscreen interface is designed so that often-used functions are within quick reach. Set peak threshold and peak excursion with the touch of a button. Maximize the table to view as many channels as possible on the display. Built-in applications are easily launched using a single toolbar button.

Spend time making measurements, not writing remote programming code to collect data. The data logging capability of the 86122A collects measurement data at user-defined intervals and saves it to a Comma Separated Variable (.csv) file. This file can then be downloaded to a spreadsheet program for further data analysis and presentation.

The graphical user interface can be operated directly using the touchscreen or by using an external keyboard and mouse.

**Spend time making measurements, not writing remote programs to collect data.**



# Manufacturing

With a choice of price/performance options, the Agilent multi-wavelength meter family allows the conscientious manufacturing engineer to select the most cost-effective measurement solution. And with the 86122A's backwards compatibility and upgradeable performance options, you can easily upgrade your test system. Your investment is protected into the future, even with fast-changing performance needs.

Agilent multi-wavelength meters offer the fastest update rate available to optimize manufacturing throughput and enable real-time measurements. With a two-year calibration cycle\*, manufacturing downtime and cost of ownership are kept to a minimum.



Since manufacturing test equipment is primarily used remotely, instrument control must be easy, reliable and robust. Agilent's multi-wavelength meters offer instrument control using SCPI (Standard Commands for Programmable Instruments) via a standard GPIB interface. Additionally, the 86122A offers a LAN interface that provides for easy data storage via network file sharing as well as SCPI over LAN control to optimize data transfer speeds.

**Your investment is protected into the future, even with fast-changing performance needs.**

Agilent multi-wavelength meters offer ease-of-use from the front panel. So, when troubleshooting is required on the manufacturing floor, it can be quickly and easily accomplished. The 86122A also offers on-line help for convenient reference.



## Installation, commissioning and monitoring

Installation, commissioning and monitoring of DWDM transmission systems require the performance you would expect in the factory coupled with the ability to withstand rough handling in the field.

The 86120B and 86120C are designed with ruggedness and portability in mind. Optimize system integrity by verifying operation easily during installation and maintenance. Agilent's multi-wavelength meters are tested under rigorous operating conditions to simulate the harsh environments that they are expected to encounter in the field. The ruggedized, portable packaging, along with an easy-to-use interface, makes them ideal tools to ensure quality service by verifying system performance.

\* Recommended calibration cycle for the high-accuracy option on the 86122A is one year.



## Ordering Info

For the most up-to-date ordering information, please contact your Agilent sales representative or visit our website at: [www.agilent.com/comms/lightwave](http://www.agilent.com/comms/lightwave).

### 86120B/C Multi-Wavelength Meter

#### Connector options

- 86120x-020 Straight contact interface - PC
- 86120x-022 Angled contact interface - APC

#### Connector adapters

- 86120x-011 HMS-10 connector adapter
- 86120x-012 FC connector adapter
- 86120x-013 DIN connector adapter
- 86120x-014 ST connector adapter
- 86120x-017 SC connector adapter

#### Fixed external 10 dB attenuators

- 86120x-412 Attenuator with FC/PC connectors
- 86120x-417 Attenuator with FC/APC connectors

#### Accessories

- 86120x-AXE Rack flange kit with handles
- 86120x-IA4 Rack flange kit without handles
- 86120x-UK5 Nylon carrying case
- 86120x-UK6 Commercial calibration certificate with test data
- 86120x-UK7 Hard carrying case

### 86122A Multi-Wavelength Meter

#### Performance Options

- 86122A-001 Standard performance
- 86122A-002 High-accuracy performance

#### Connector options

- 86122A-020 Straight contact interface - PC
- 86122A-022 Angled contact interface - APC
- 86122A-400 Front-panel fiber input
- 86122A-401 Rear-panel fiber input

#### Connector adapters

- 81000AI HMS-10 connector adapter
- 81000FI FC connector adapter
- 81000SI DIN connector adapter
- 81000UI ST connector adapter
- 81000KI SC connector adapter

#### Fixed external 10 dB attenuators

- 86122A-412 Attenuator with FC/PC connectors
- 86122A-417 Attenuator with FC/APC connectors

#### Accessories

- 86122A-1CM Rack mount kit without handles
- 86122A-1CN Handle kit
- 86122A-1CP Rack mount plus handles kit
- 86122A-UK6 Commercial calibration certificate with test data

## Agilent Technologies MWM family — A whole product solution

The performance of Agilent's multi-wavelength meter family is only a small part of what you get from Agilent Technologies. Agilent strives to provide complete solutions that go beyond our customer's expectations. Only Agilent offers the depth and breadth of enhancements, software, services, connectivity, accessibility and support to help our customers reach their measurement objectives.



# MWM Family

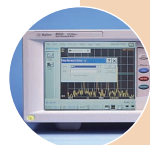

### PC connectivity

- VXI plug and play drivers
- LAN, Parallel, VGA, GPIB, Mouse, and Keyboard ports



### Pre-sales service

- Rentals, leasing, and finance
- Application engineering services
- Application and product notes



### Post-sales support

- Standard one-year global warranty
- Two-year calibration cycle (one-year recommended for 86122A with high-accuracy option)
- Worldwide call center and service center support network



### Serviceability

- Recovery disk to restore factory defaults
- Instrument repair available at local service centers

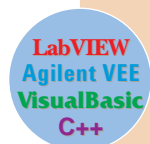

### Instrument drivers

- SCPI (Standard Commands for Programmable Instruments)
- Instrument drivers available



### Training and access to information

- English and Japanese manuals available in hardcopy or via the web
- On-line help in English or Japanese
- Application notes



### Firmware upgrade via the Internet

- Download directly to instrument via LAN
- Download to floppy disk
- Web: [www.agilent.com/comms/mwmupgrade](http://www.agilent.com/comms/mwmupgrade)



## **Agilent Technologies' Test and Measurement Support, Services, and Assistance**

Agilent Technologies aims to maximize the value you receive, while minimizing your risk and problems. We strive to ensure that you get the test and measurement capabilities you paid for and obtain the support you need. Our extensive support resources and services can help you choose the right Agilent products for your applications and apply them successfully. Every instrument and system we sell has a global warranty. Support is available for at least five years beyond the production life of the product. Two concepts underlie Agilent's overall support policy: "Our Promise" and "Your Advantage."

### **Our Promise**

Our Promise means your Agilent test and measurement equipment will meet its advertised performance and functionality. When you are choosing new equipment, we will help you with product information, including realistic performance specifications and practical recommendations from experienced test engineers. When you use Agilent equipment, we can verify that it works properly, help with product operation, and provide basic measurement assistance for the use of specified capabilities, at no extra cost upon request. Many self-help tools are available.

### **Your Advantage**

Your Advantage means that Agilent offers a wide range of additional expert test and measurement services, which you can purchase according to your unique technical and business needs. Solve problems efficiently and gain a competitive edge by contracting with us for calibration, extra-cost upgrades, out-of-warranty repairs, and on-site education and training, as well as design, system integration, project management, and other professional engineering services. Experienced Agilent engineers and technicians worldwide can help you maximize your productivity, optimize the return on investment of your Agilent instruments and systems, and obtain dependable measurement accuracy for the life of those products.

**By internet, phone, or fax, get assistance with all your test & measurement needs.**

### **Online assistance:**

[www.agilent.com/comms/lightwave](http://www.agilent.com/comms/lightwave)

### **Phone or Fax**

#### **United States:**

(tel) 1 800 452 4844

#### **Canada:**

(tel) 1 877 894 4414  
(fax) (905) 282 6495

#### **China:**

(tel) 800-810-0189  
(fax) 1-0800-650-0121

#### **Europe:**

(tel) (31 20) 547 2323  
(fax) (31 20) 547 2390

#### **Japan:**

(tel) (81) 426 56 7832  
(fax) (81) 426 56 7840

#### **Korea:**

(tel) (82-2) 2004-5004  
(fax)(82-2) 2004-5115

#### **Latin America:**

(tel) (305) 269 7500  
(fax) (305) 269 7599

#### **Taiwan:**

(tel) 080-004-7866  
(fax) (886-2) 2545-6723

#### **Other Asia Pacific Countries:**

(tel) (65) 375-8100  
(fax) (65) 836-0252  
Email: [tm\\_asia@agilent.com](mailto:tm_asia@agilent.com)

Product specifications and descriptions in this document subject to change without notice.

© 2002 Agilent Technologies, Inc.  
Printed in USA February 1, 2002  
5988-5095EN



**Agilent Technologies**